

Light Theory

Light sources

A light source is something that produces light. This can be a natural source, such as the Sun or a glow-worm, or an artificial source, such as a light bulb or candle. Most objects do not produce light. Instead, they either reflect, absorb or scatter the light given out by a light source. Light can also travel through transparent objects.

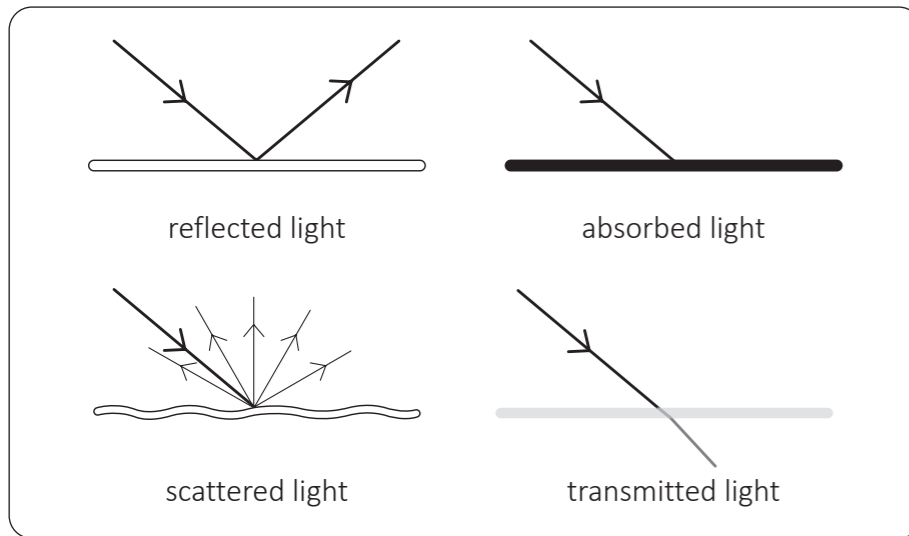

How does light travel?

Light is a form of energy that travels as waves in straight lines. In diagrams, light waves are drawn as straight lines with arrowheads that show the direction of travel.

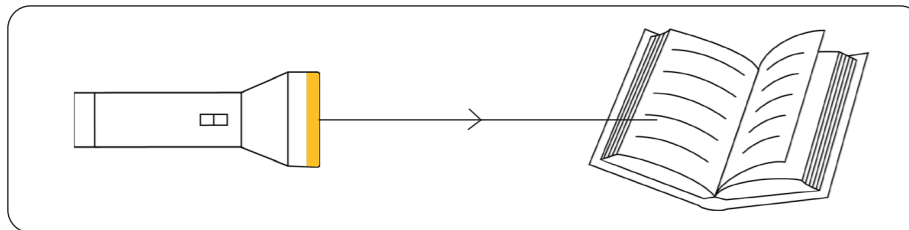

Light continues to travel when it is reflected off the surface of an object. When light hits a mirror, it reflects off the surface in a straight line. All mirrors reflect light at an angle equal to the angle of impact.

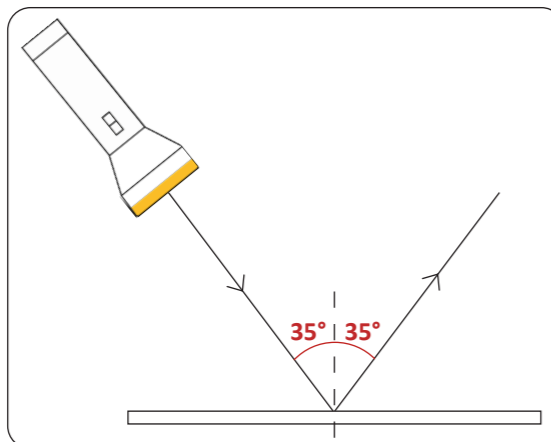

Light and sight

For us to see any object, light must enter our eyes. Light rays can travel to our eyes directly from a light source, so we can see the light source.

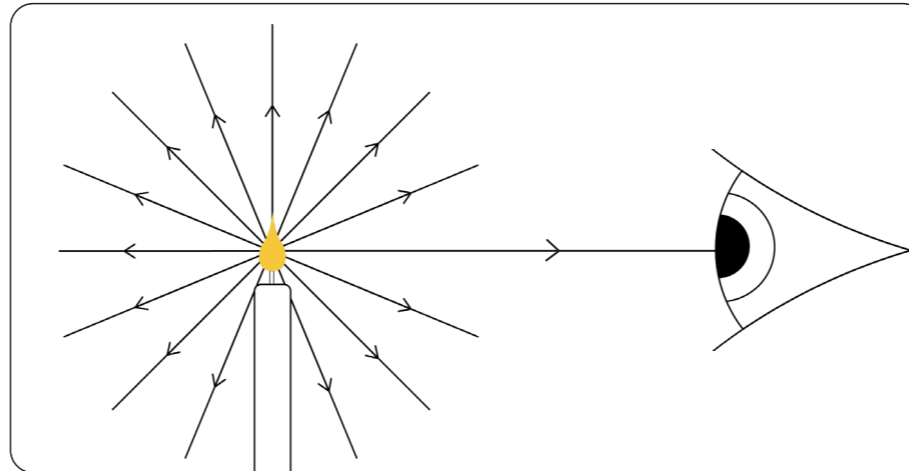

Light can also travel to our eyes after it has been scattered or reflected. In this diagram, light from the torch travels to the book and is then reflected from the book into the person's eye.

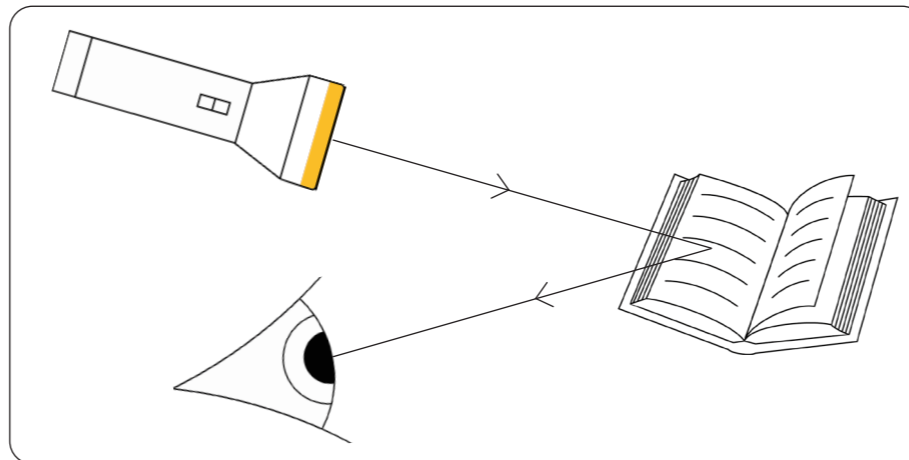

Light rays reach the eye and travel through the cornea before entering the eye through the pupil. The lens focuses the light onto the back of the eye, called the retina. The retina turns this light information into electrical signals, which travel through the optic nerve to the brain, where the signals are 'seen' as an image. Without light, we cannot see.

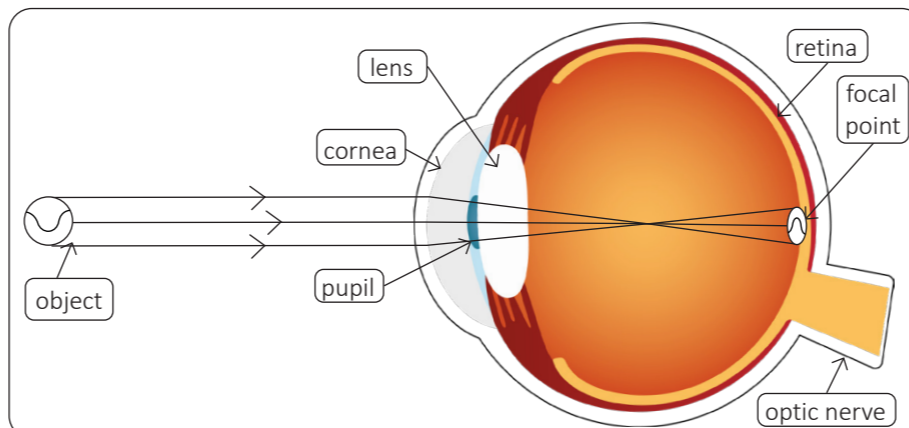

Electromagnetic spectrum

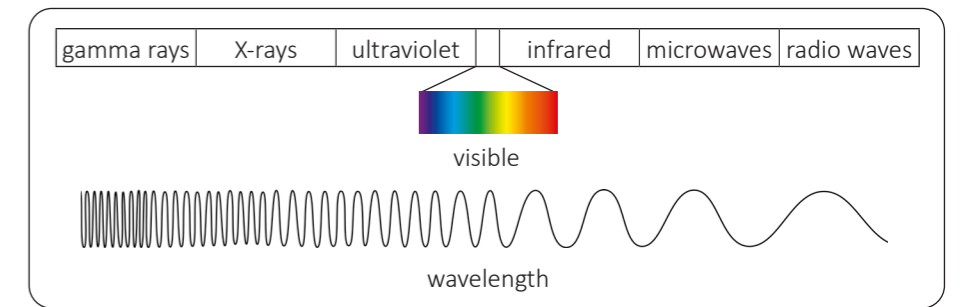

The electromagnetic spectrum shows all the different types of light, from gamma rays with waves that are close together, to radio waves with waves that are far apart. Visible, or white light is the only light the human eye can see and is only a small part of the electromagnetic spectrum.

Visible light

Visible light is made up of a continuous spectrum of different colours of light, from violet to red. All the colours of light mix together to create white light.



The way objects reflect or absorb light determines their colour.

Some objects reflect all the colours of light, so we see those as white.

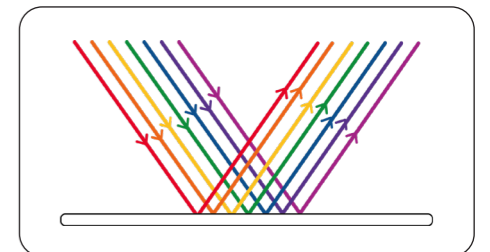

Other objects absorb some of the colours in white light, but some colours are reflected. We see these objects as the coloured light that is reflected.

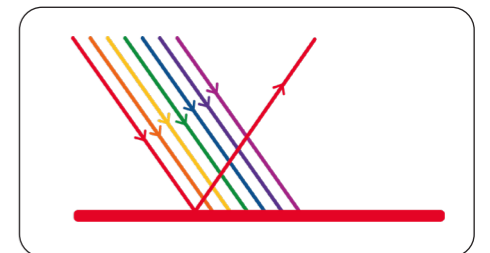

Black objects absorb all the colours of white light.

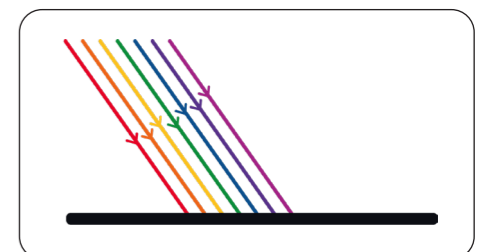

Perceiving colour

Light enters our eyes through the pupil and is focused onto light-sensitive cells called rods and cones that cover the retina at the back of the eye. Rods help us to see light and dark and cones help us to see different colours. Once the cone cells have been stimulated, a signal is sent to the brain through the optic nerve. The brain interprets the signal as a particular colour, giving us colour vision.

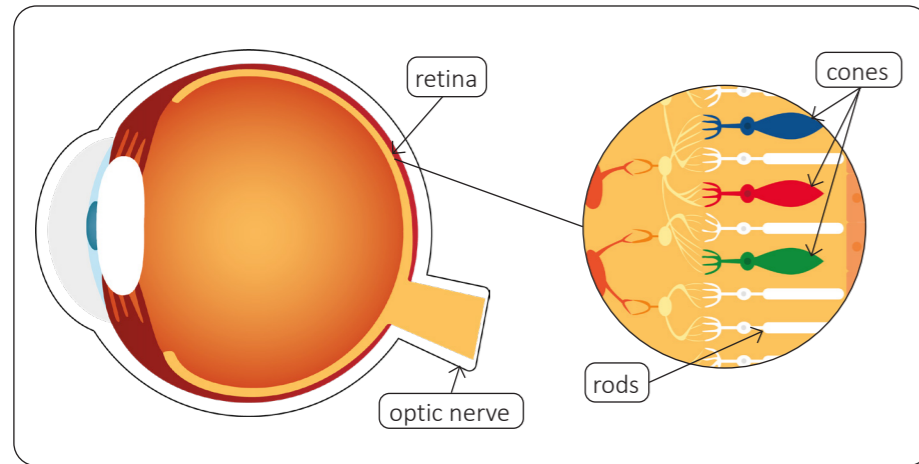

Red, green and blue are the primary colours of light. When the red and green cones in our eyes are stimulated, we perceive a yellow colour. When the blue and green cones are stimulated, we perceive a cyan colour. When the red and blue cones are stimulated, we perceive a magenta colour. If the red, green and blue cones are all stimulated, we see white.

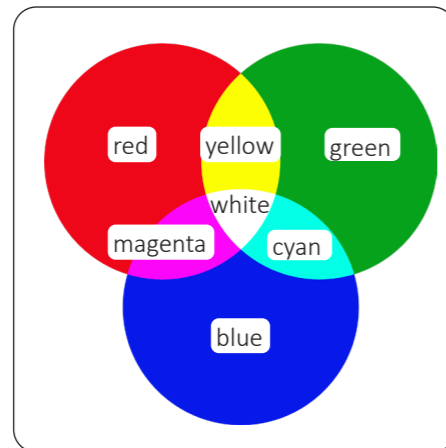

Shadows

Shadows form when an object blocks the passage of light, leaving an area of darkness. The size and length of an object's shadow can vary depending on the position of the light source.



Reflection in different mirrors

There are three main types of mirror: plane, concave and convex. A plane mirror has a flat reflective surface, so perpendicular light rays are reflected back along the same path. This means the reflected image is the same size and the same way up as the object, but the image is reversed.

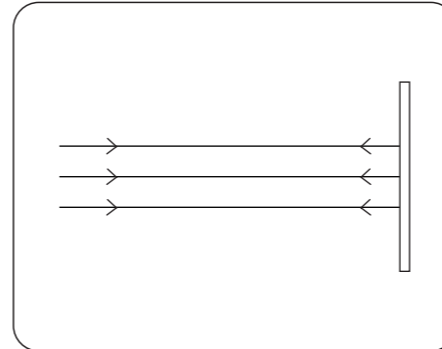

plane mirror

The surface of a concave mirror curves inwards, so light rays are reflected inwards to a focal point. Images appear larger and brighter in a concave mirror, but they reflect a narrower view. Dental mirrors and torches use concave mirrors.

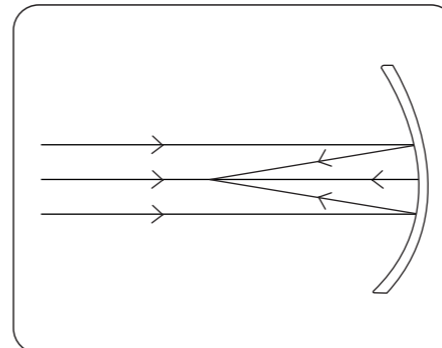

concave mirror

The surface of a convex mirror curves outwards, so light rays are reflected outwards and dispersed. Convex mirrors make images smaller, but they reflect a wider view. Shop security mirrors and car wing mirrors are convex.

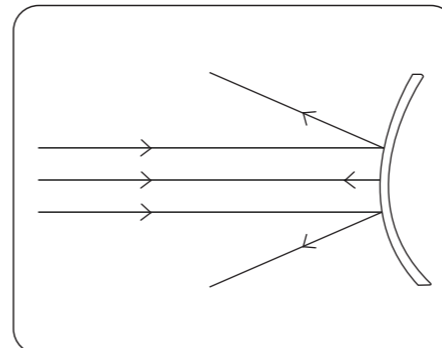

convex mirror

Refraction

Refraction is the change in direction of light as it passes from one transparent material to another. This diagram shows a light ray travelling in a straight line through the air, then hitting the surface of the water. Water is denser than air because water is a liquid and air is a gas, so the light slows down and changes direction.

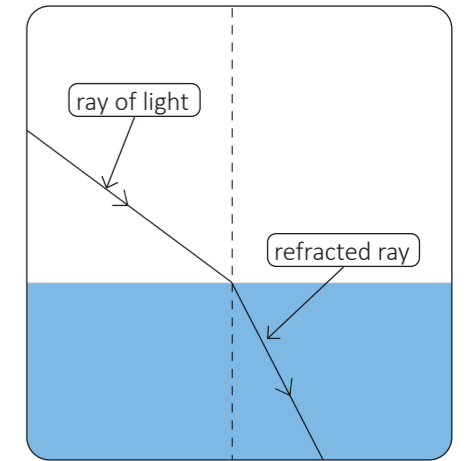

When white light travels through a triangular prism, light is refracted twice. This, along with the prism's angled edges, splits white light into a spectrum of colours from red to violet.

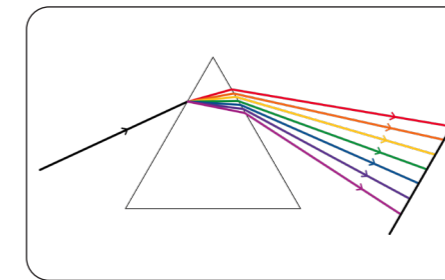

Refraction creates different phenomena on Earth. For example, light refracted by raindrops creates a rainbow. Light refracted by a glass of water can make a straw look bent or disjointed.

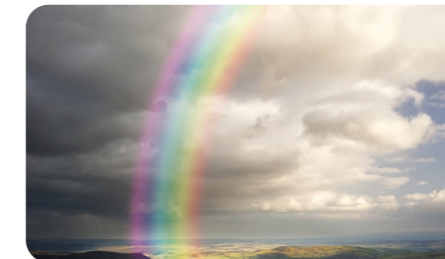

Glossary

absorb	The ability to soak something up, such as a liquid or light.
reflect	To bounce off a surface.
scatter	To move apart in different directions.
spectrum	A band of colours produced when white light is separated.
visible light	The part of the electromagnetic spectrum that the human eye can see, also known as white light.

